

SOLID PIN TERMINAL
42023-1***

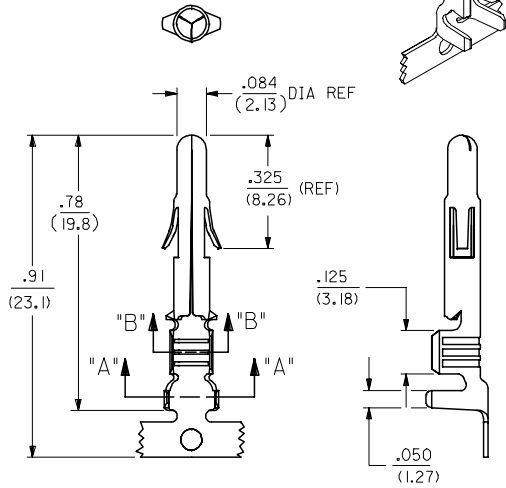

SPLIT PIN TERMINAL
42023-2***

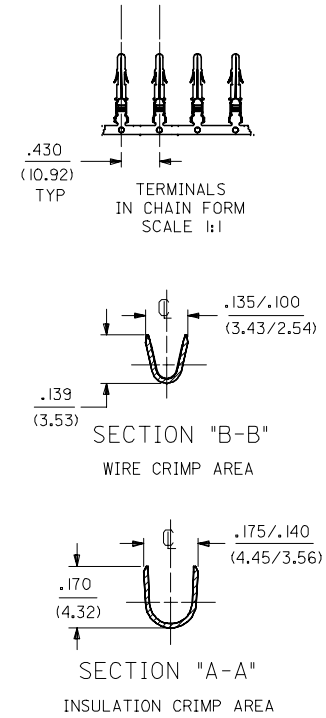
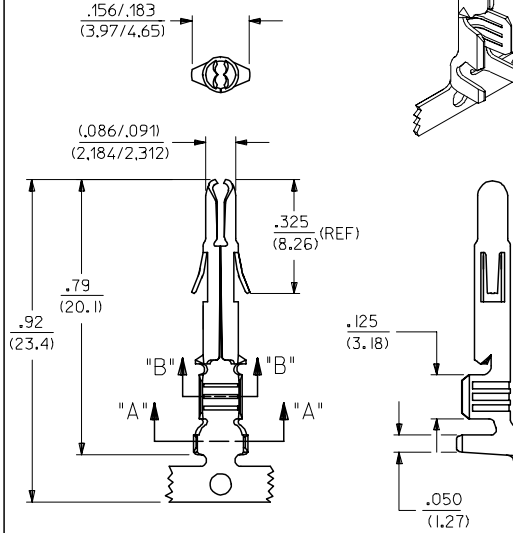

SEE SHEET2 FOR CHART, MATERIAL, PLATING, NOTES, AND CRIMP OPTIONS

EC NO: 12005-0302 DRAWN: SUDHIR 2004/09/27 CHKD: KPRASAD 2004/09/27 APPR: KPRASAD 2004/09/27	QUALITY SYMBOLS ▽=0 ▽=0	GENERAL TOLERANCES (UNLESS SPECIFIED)		DIMENSION STYLE IN/MM		SCALE 4:1	DESIGN UNITS INCH	THIRD ANGLE PROJECTION	
		4 PLACES ± --- ± ---	mm INCH	DRAWN BY SUDHIR	DATE 2004/09/24	TITLE TERMINAL, PIN .084/(2.13) DIA. SERIES			
		3 PLACES ± --- ± .010		CHECKED BY KPRASAD	DATE 2004/09/24	MOLEX INCORPORATED			
		2 PLACES ± 0.25 ± .015 1 PLACE ± 0.38 ± --- ANGULAR ± 1/2°		APPROVED BY KPRASAD	DATE 2004/09/24	MATERIAL NO. SEE CHART	DOCUMENT NO. SD-42023-****	SHEET NO. 1 OF 2	
DRAFT WHERE APPLICABLE MUST REMAIN WITHIN DIMENSIONS		SIZE A2		THIS DRAWING CONTAINS INFORMATION THAT IS PROPRIETARY TO MOLEX INCORPORATED AND SHOULD NOT BE USED WITHOUT WRITTEN PERMISSION					

ENG. NO.	EDP NO.	FINISH (REF)	CONTACT AREA (REF)	CRIMP AREA (REF)	MATERIAL (REF)	TERMINAL TYPE	WIRE SIZE	INSULATION DIAMETER
X-42023-1A1	PRELIMINARY	SDES-88-P901	----	----	C26000	SOLID	#14-#20 AWG	.060-.130
X-42023-1AIL	PRELIMINARY	SDES-88-P901	----	----	C26000	SOLID	#14-#20 AWG	.060-.130
42023-2A1	002-08-2003	SDES-88-P901	----	----	C26000	SPLIT	#14-#20 AWG	.060-.130
42023-2AIL	002-08-2004	SDES-88-P901	----	----	C26000	SPLIT	#14-#20 AWG	.060-.130
42023-2B1	002-08-2005	SDES-88-P901	----	----	C51000	SPLIT	#14-#20 AWG	.060-.130
42023-2B1L	002-08-2006	SDES-88-P901	----	----	C51000	SPLIT	#14-#20 AWG	.060-.130
42023-2A2	002-08-2007	SEE NOTE 5	.000030 MIN GOLD	.000100 MIN MATTE TIN	C26000	SPLIT	#14-#20 AWG	.060-.130
42023-2A2L	002-08-2008	SEE NOTE 5	.000030 MIN GOLD	.000100 MIN MATTE TIN	C26000	SPLIT	#14-#20 AWG	.060-.130
42023-2B2	002-08-2009	SEE NOTE 5	.000030 MIN GOLD	.000100 MIN MATTE TIN	C51000	SPLIT	#14-#20 AWG	.060-.130
42023-2B2L	002-08-2010	SEE NOTE 5	.000030 MIN GOLD	.000100 MIN MATTE TIN	C51000	SPLIT	#14-#20 AWG	.060-.130

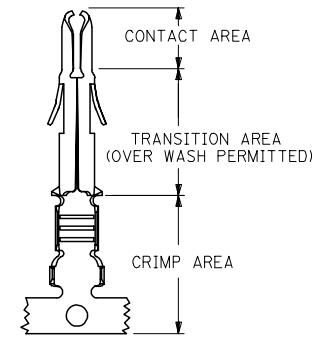

PLATING REGIONS

APPLIES TO GOLD PLATED TERMINALS ONLY

NOTES:

1) PIN TERMINALS FOR USE WITH THE .084/(2.13) SERIES HOUSINGS:

- PLUG (42021-**) CAP (42022-**)

2) PIN TERMINALS MATE WITH SOCKET TERMINALS: .084/(2.13) DIA. SERIES (42024-****).

3) TERMINALS FINISHED IN CHAIN UNLESS SPECIFIED LOOSE. "L" SUFFIX INDICATES LOOSE FORM. (SEE TABLE)

4) MATERIAL: .012/(0.30) THICK STRIP:
 A = BRASS, *C26000, PER SMES-124-C7.
 B = PHOSPHOR BRONZE, *C51000, PER SMES-124-E7.

5) FINISH:
 1 = HOT TIN DIP 20 m.l./(.51 MICRONS) MINIMUM (PER SDES-88-P901).
 2 = 30 M.I (0.75 MICRONS) MIN GOLD & 100 M.I (2.50 MICRONS) MIN SELECT TIN
 50 M.I (1.25 MICRONS) MIN NICKEL OVERALL

6) CRIMP RANGE: SCC CIAR1.

7) PRODUCT SPECIFICATION PS-42022-0001 APPLIES.

LEGEND:

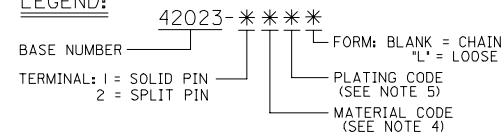

EC NO: 12005-0302 DRAWN: SUDHIR 2004/09/27 CHKD: KPRASAD 2004/09/27 APPR: KPRASAD 2004/09/27	QUALITY SYMBOLS ▽=0 ▽=0	GENERAL TOLERANCES (UNLESS SPECIFIED)		DIMENSION STYLE IN/MM	SCALE ---	DESIGN UNITS INCH	THIRD ANGLE PROJECTION	
		4 PLACES ± --- ± --- 3 PLACES ± --- ± --- 2 PLACES ± --- ± --- 1 PLACE ± --- ± --- ANGULAR ± --- °	DRAWN BY DATE SUDHIR 2004/09/27	CHECKED BY DATE KPRASAD 2004/09/27	TITLE TERMINAL, PIN .084/(2.13) DIA. SERIES			
		DRAFT WHERE APPLICABLE MUST REMAIN WITHIN DIMENSIONS	APPROVED BY DATE KPRASAD 2004/09/27	MOLEX INCORPORATED				
		MATERIAL NO. SEE CHART		DOCUMENT NO. SD-42023-****		SHEET NO. 2 OF 2		